

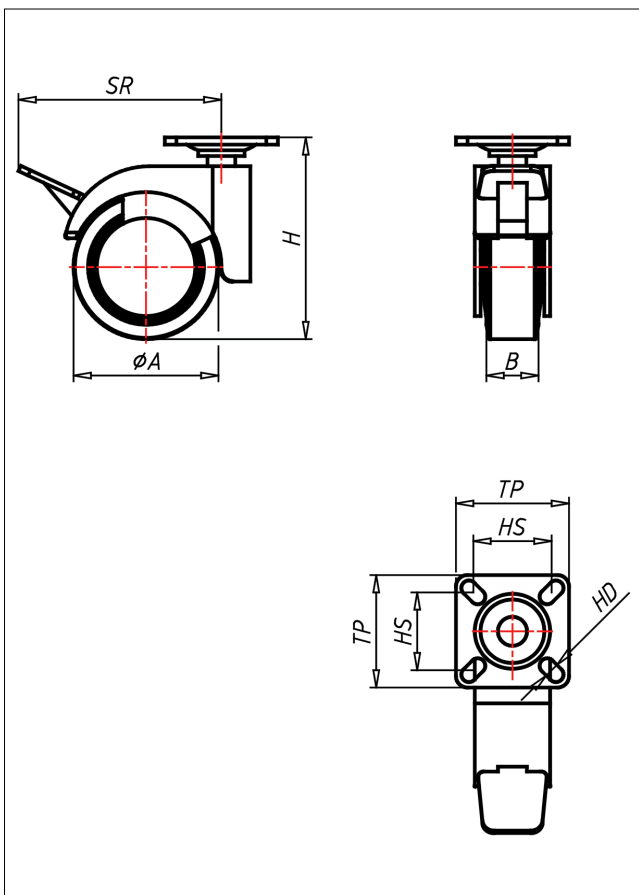

476 PT G

Lenkrolle mit Radfeststeller

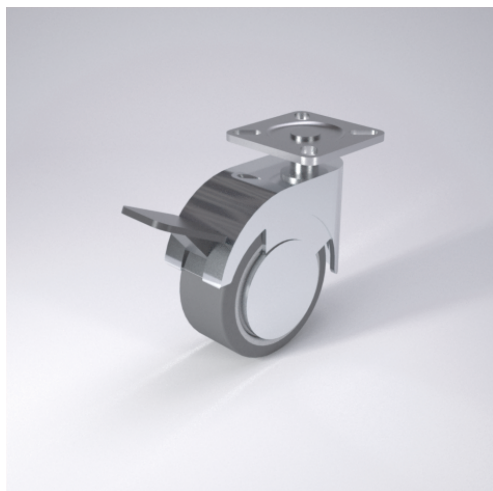

475-G



+60 °C
-20 °C

max.
40 kg



Gehäuse: Zinkdruckguss - verchromt
Schwenklager mit kombiniertem
Gleit-Kugellager
Felge Polyamid 6
grauer Gummirreifen - spurfrei
Radfeststeller glasfaserverstärkt
Radachse verschraubt

Technische Details

ORDERNO (Artikel-nummer)	476 PT 50 GK
WDAB (Rad-Ø A x Breite B / mm)	50x18
LC (Tragkraft / kg)	40
H (Bauhöhe H / mm)	70
TP (Plattengröße / mm)	39x39
HS (Lochabstand / mm)	30x30/24x24
HD (Loch-Ø / mm)	5.2
SR (Schwenkradius / mm)	70
WB (Radlager)	Kugellager